

Ultra Low-power Inductively Coupled Wearable ECG Sensor Design with Inkjet Printed Dry Electrodes

Bashir I. Morshed
Electrical and Computer Engineering
University of Memphis
Memphis, TN 38152 USA
bmorshed@memphis.edu

Abstract—Wearable Electrocardiogram (ECG) devices cannot be used for long duration due to power requirement (on a single charge) and electrode degradation. A new extremely low power wearable ECG sensor device is proposed in this work that minimizes power consumption by eliminating digitization and wireless data transfer with a zero power analog inductive coupling and long duration inkjet printed (IJP) dry electrodes. The prototyped device can operate on a coin cell for 140 hours consuming only 1.6 mA. Ability to collect ECG data at home for long duration can largely improve capabilities of mobile health (mHealth) towards Smart and Connected Communities (SCC).

I. INTRODUCTION

Electrocardiography (ECG/EKG) systems have progressed from large stationary bench setup to miniature wearable or body-worn systems [1]. Related challenges that are preventing further miniaturization include power consumption and long-time operation of ECG electrodes. Inkjet printing (IJP) is a new additive fabrication technology that can deposit materials (in ink form) to planar substrates (such as paper) with high precision (a few micron) achieving consistent thin film profile (in the range of micron). We have previously reported an IJP electrode for ECG data capture that operates for a long duration (several days) without degradation [2]. In this paper, we report a new design scheme for an ultra low-power wearable ECG sensor system that incorporates the IJP ECG electrodes.

II. CONCEPT

Fig. 1a shows a typical ECG sensor system that includes ECG electrodes, differential amplifier followed by filter and other analog signal processing circuitry (e.g. variable gain amplifier), an analog-to-digital converter (ADC), an optional microcontroller unit (MCU) for data buffer and management of the wireless module, and a wireless module (typically Bluetooth or BLE). In addition, if the circuit is powered with rechargeable battery (e.g. LiPo), a charge management circuitry will be needed (not shown).

Fig. 1b also shows the proposed ECG sensor system that eliminates the most power hungry element: the wireless module. Typical Bluetooth module requires 50 - 70 mA current during transmission which might be an order higher compared to other modules on the wearable ECG sensor system. Instead of the typical wireless module, we have used inductive loading principle that is developed through our Wireless Resistive Analog Sensor (WRAP) sensor research work [3,4]. Inductive

loading technique does not consume any power from the sensor itself, hence leads to a low-power design. Furthermore, data through inductive coupling can be transferred in analog mode (e.g. amplitude modulation), which also eliminates the need for the ADC and MCU. However, a voltage-to-impedance transducer is needed to interface the analog output and the transmitter coil, when we have realized with a single transistor.

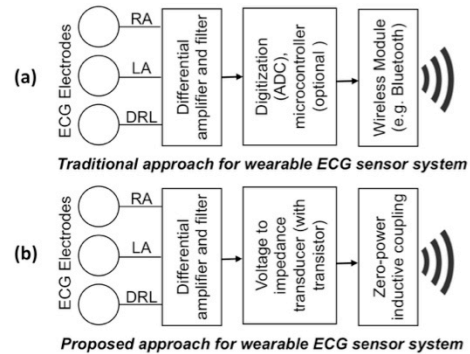

Fig. 1. (a) Traditional wearable ECG sensor system. (b) The proposed ECG sensor system.

III. DESIGN DESCRIPTION

Fig. 2 shows the complete KiCad schematic circuit diagram of the prototyped ECG sensor. Note that the planar spiral coil (PSC) and ECG electrodes are not part of KiCad schematic and are shown for illustration purpose only. The designed KiCad EDA files (schematic, layout, and gerber) are made open access via Github (<https://github.com/esarplab/ECG-device>).

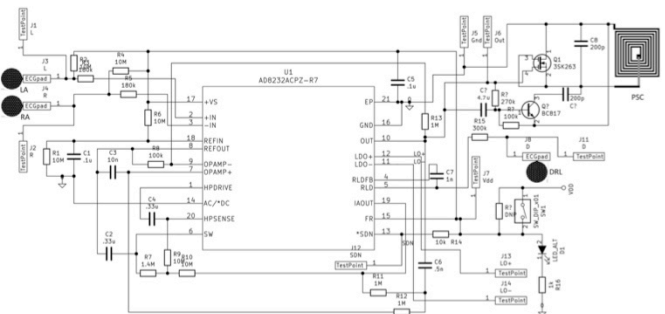

Fig. 2. Schematic diagram of the proposed ECG sensor.

The differential amplifier, filter, and gain is performed with a commercial single-lead analog front end (AFE) integrated

chip (AD8232, Analog Devices Inc.). AD8232 amplifies the ECG signals from the electrodes using the internal Instrument Amplifier (IA) and filters. The output can be applied to either a MOSFET (depletion mode) [4] or a BJT amplifier [3]. The results here are only based on the BJT amplifier. The transistor acts as a resistive load to the PSC coil for inductive coupling. The inductive coupling is probed with a scanner device (not shown here) that transmits ISM band RF signal (7 - 13.56 MHz). The modulation of envelope of the carrier signal is captured by the scanner [3].

The schematic design was used to develop a 2-layer PCB using KiCad as shown in Fig. 3. The top layer contained all the components and testpads, while the bottom layer contained 5 exposed copper plates that allow direct taping of the IJP electrodes and the PSC printed on paper. The PCB design was fabricated via Oshpark 2-layer PCB service (Oshpark LLC).

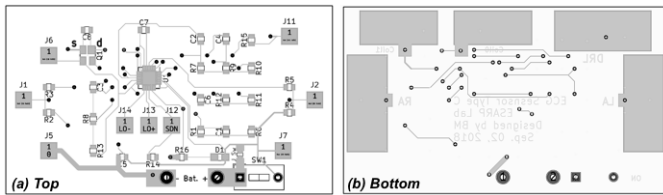

Fig. 3. Layout of the PCB: (a) Top layer and (b) Bottom layer.

The IJP electrodes were printed with Ag nanoparticle ink (B25, Novacentrix) using an IJP printer (DMP2831, FujiFilm Dimatix Inc.) on the glossy side of a 10.4 mil photopaper (Kirkland Signature, Costco). We have previously reported details of this IJP dry electrodes [2] and PSC design [5]. The complete IJP layout contains 3 ECG electrodes (LA, RA, and DRL) and a PSC coil. We have spaced LA and RA ECG electrodes by 20 cm, but this can be easily modified and customized as per individual and ECG Lead need. This ease of personalized customization is an added advantage of the IJP process. The layout also contains the pads corresponding to the bottom layer of the PCB and attached using polyamide tape. The populated PCB with IJP electrodes and coil, along with a coin cell battery and a switch weighs only 17.9 grams (Fig. 4).

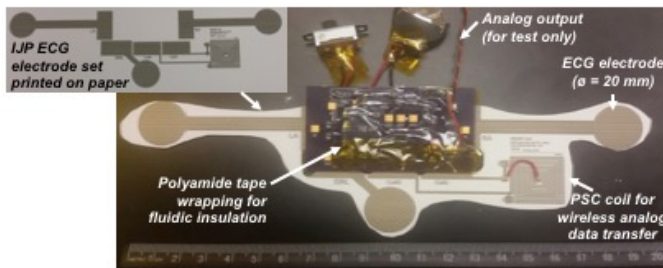

Fig. 4. A photograph of the fabricated and populated ECG sensor PCB attached with IJP electrodes and PSC on paper.

IV. RESULTS

The prototyped ECG device was tested and verified to collect ECG data from finger and chest configurations. Fig. 5 shows a set of data from chest configuration. The signal shows interference from utility line noise, which is removed with a 6th order Butterworth Low pass filter with $f_c = 40$ Hz (Fig. 6). The inductively coupled signal also need and inversion

operation as the envelope signal is inverted related to ECG output signal. The current consumption of the proposed ECG sensor system is only 1.6 mA, which allows a CR2032 (3V Lithium coin cell battery) to continuously operate for 140 hrs.

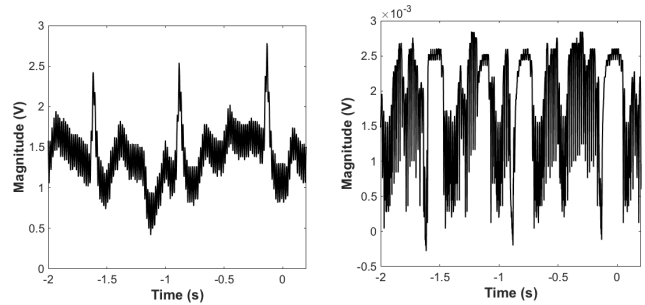

Fig. 5. A segment of ECG signals from the analog output (left) and from the inductively coupled envelope detector (right).

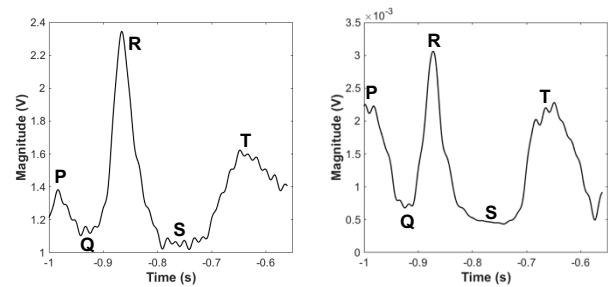

Fig. 6. An ECG beat from the analog output (left) and the inductively coupled signal (right) after signal processing.

V. CONCLUSIONS

We report an ultra low-power wearable ECG sensor design that uses zero-power inductive coupling and eliminates digitization and wireless transmission. We have demonstrated the prototype with IJP dry ECG electrodes to collect signals for long durations. Future work will improve the signal quality, minimize nonlinearity, optimize design, and reduce noise.

ACKNOWLEDGEMENT

This material is based upon work supported by the National Science Foundation under Grant No. 1637250 and FIT Foundation Fund Technology Development Grant 20715.

REFERENCES

- [1] Y. Zheng, et al. "Unobtrusive Sensing and Wearable Devices for Health Informatics", IEEE Trans Biomedical Engineering, vol. 61, no. 5, pp. 1538-1554, May 2014.
- [2] A. Mohapatra, B. I. Morshed, S. Shamsir, and S. K. Islam, "Inkjet Printed Thin Film Electronic Traces on Paper for Low-cost Body-worn Electronic Patch Sensors", IEEE conf Body Sensor Networks (BSN), Las Vegas, NV, pp. 169-172, 2018.
- [3] B. I. Morshed, B. Harmon, M. S. Zaman, M. J. Rahman, S. Afroz, and M. Rahman, "Inkjet Printed Fully-passive Body-worn Wireless Sensors for Smart and Connected Community (SCC)", J. Low Power Electron. Appl., vol. 7, no. 4, article 26, pp. 1-21, Nov. 2017.
- [4] S. Consul-Pacareu, and B. I. Morshed, "Design and analysis of a novel wireless resistive analog passive sensor technique", IET Wireless Sensor Systems, vol. 8, no. 2, pp. 45-51, 2018.
- [5] B. Noroozi and B. I. Morshed, "PSC Optimization of 13.56-MHz Resistive Wireless Analog Passive Sensors", IEEE Trans. Microwave Theory and Techniques, vol. 65, no. 9, pp. 3548-3555, Sept. 2017.